

# R&J WELDING & METAL FABRICATION

COIN SECURITY LAUNDRY PRODUCTS



ORDERING CATALOG

[www.RJMetalFabrication.com](http://www.RJMetalFabrication.com)

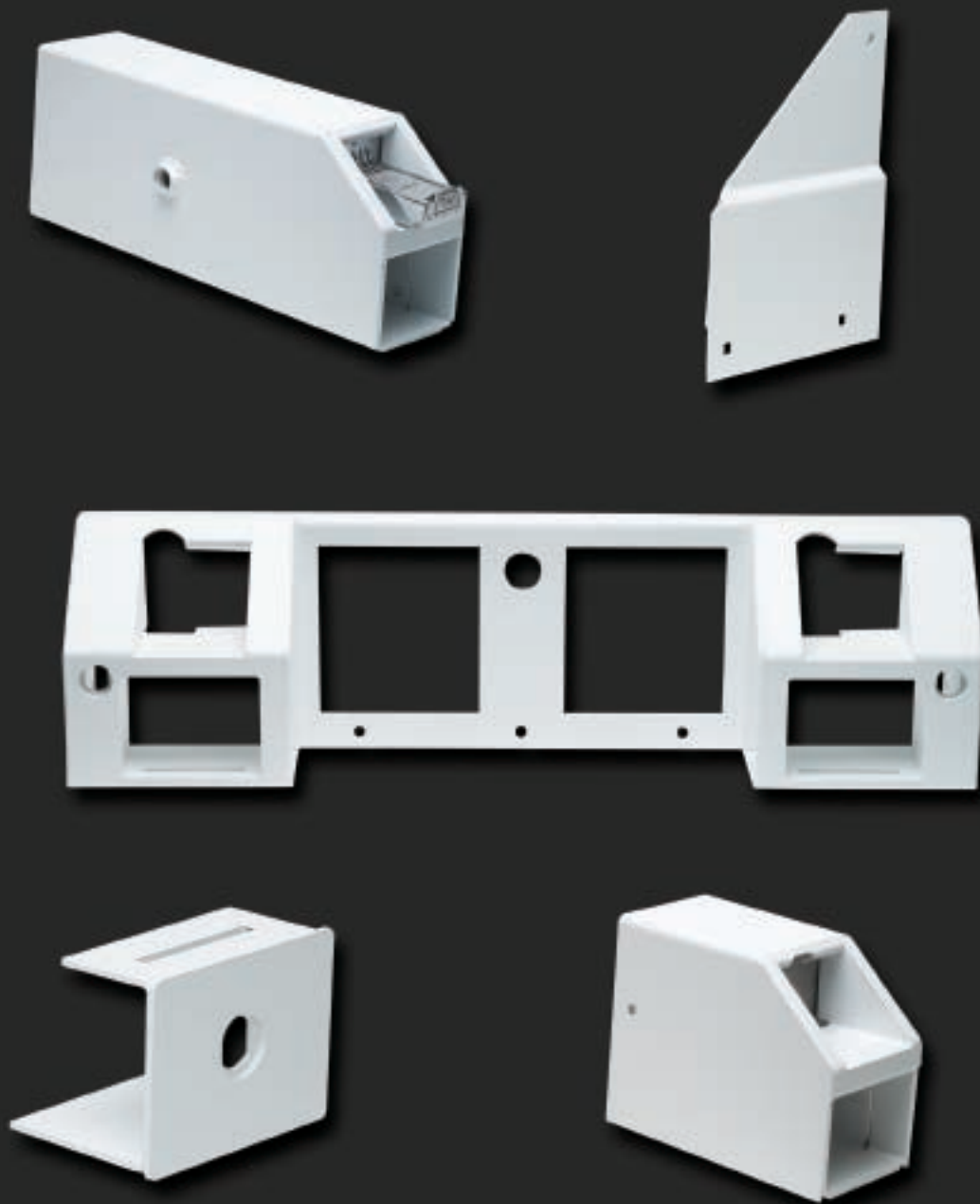

**RJ** WELDING & METAL FABRICATION

2182 E. Maple Privado  
Ontario, CA 91761

Tel: **909. 930. 2900**  
Fax: 909. 930. 2990

Email: [jaserjwelding@yahoo.com](mailto:jaserjwelding@yahoo.com)  
Website: [www.RJMetalFabrication.com](http://www.RJMetalFabrication.com)

Specially  
Designed  
For

# The Secure Edge Above The Competition

GENERAL  
ELECTRIC



MAYTAG



SPEED  
QUEEN



WHIRLPOOL



## EXTENDED BACK GUARD BODY

Speed Queen Open Front EB - 10 - 20  
Works on coin drop and coin slide

## Categories

General Electric	03
Speed Queen	04 - 10
Maytag	11 - 13
Whirlpool	14 - 15
Accessories	16 - 18
Partial Security	19

1/8 Metal Thickness • Maximum Security • High Standards



## New Style Open Front

Open Front does not require to be removed in order to collect moneybox. Avoid uncollectible washes with a completely covered service door. Coin Slide is fully protected all the way around to prevent damage. All parts are manufactured with 1/8 thickness metal material to assure full protection. All parts are zinc plated to avoid rusting and electro powder coating white (almond color available by request).

No. EB - 40

No. GB - 40  
(For extra security "Side Plate - SP2"  
can be attached)

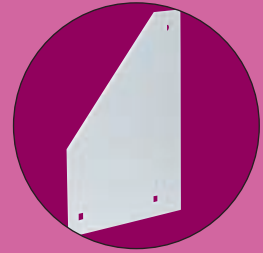

Side Plate SP-2  
(Sold Separately)

Also available for  
GE Old Style  
No. EB-30 / GB-30

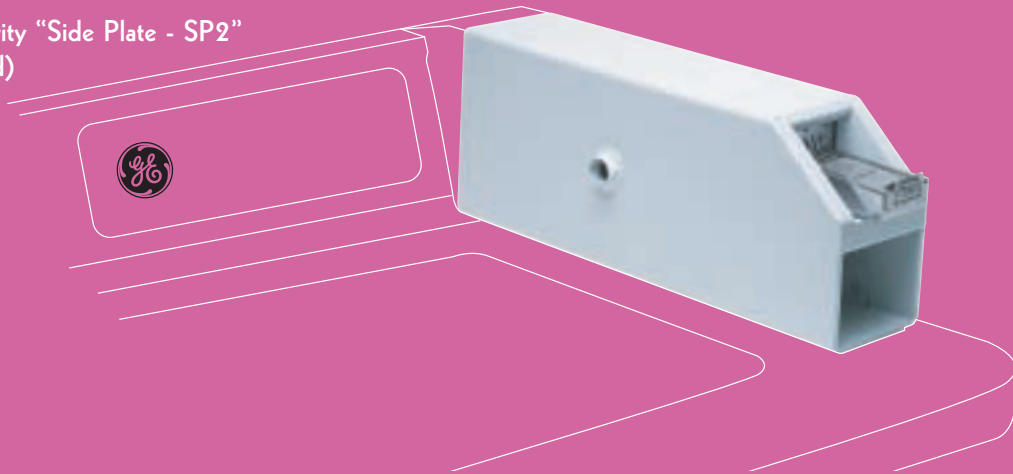

## New Style Closed Front

Close front is more secure by full protection of the money box. Guard body needs to be removed in order to collect money box. Avoid uncollectible washes with a completely covered service door. Coin Slide is fully protected all the way around to prevent damage. All parts are manufactured with 1/8 thickness metal material to assure full protection. All parts are zinc plated to avoid rusting and electro powder coating white (almond color available by request).

No. EB - 45

No. GB - 45  
(For extra security "Side Plate - SP2"  
can be attached)

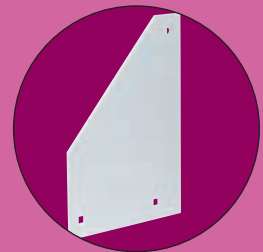

Side Plate SP-2  
(Sold Separately)

Also available for  
GE Old Style  
No. EB-35 / GB-35

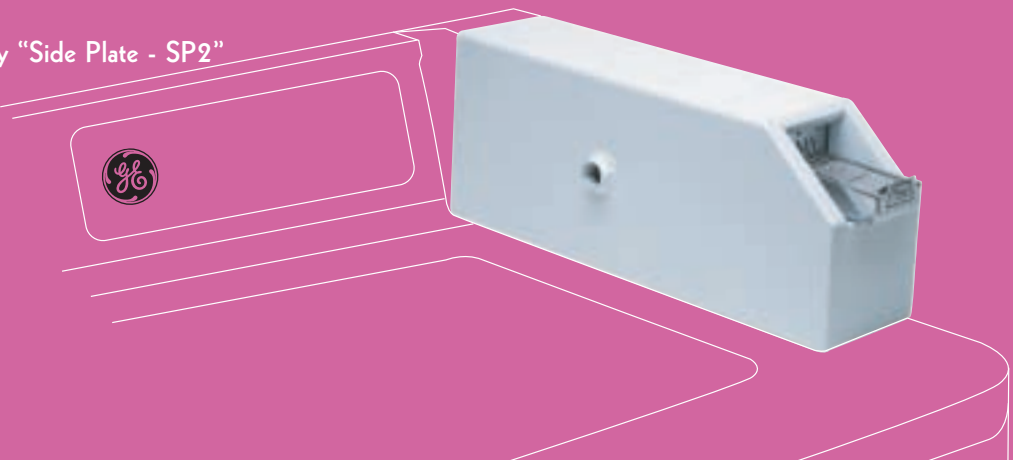

# EXTENDED BACK GUARD BODY

## Open Front™

Open Front does not require to be removed in order to collect moneybox. Avoid uncollectible washes with a completely covered service door. Coin Slide is fully protected all the way around to prevent damage. All parts are manufactured with 1/8 thickness metal material to assure full protection.

No. EB - 10

All parts are zinc plated to avoid rusting and electro powder coating white (almond color available by request).

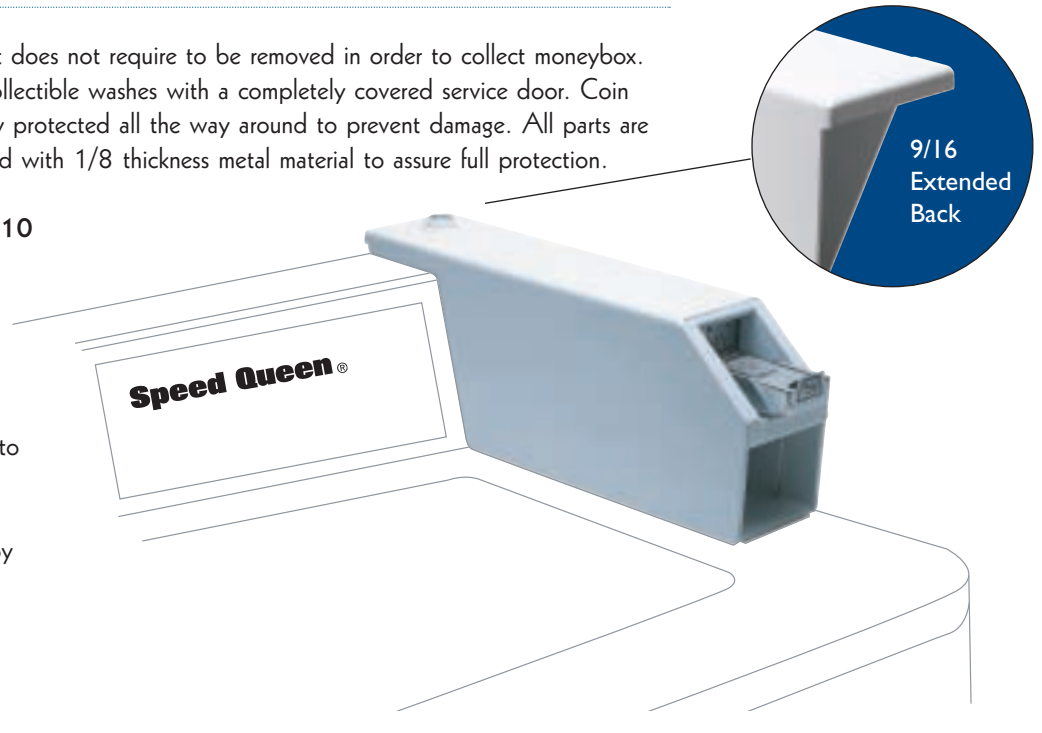

# GUARD AND BACKPLATE

## Open Front™

Open Front does not require to be removed in order to collect moneybox. Avoid uncollectible washes with a completely covered service door. Coin Slide is fully protected all the way around to prevent damage. All parts are manufactured with 1/8 thickness metal material to assure full protection. All parts are zinc plated to avoid rusting and electro powder coating white (almond color available by request).

No. GB - 10

Back plate gives you full security on the back, bolted with two 5/16 x 3/4 step bolts and 2 hex nuts.

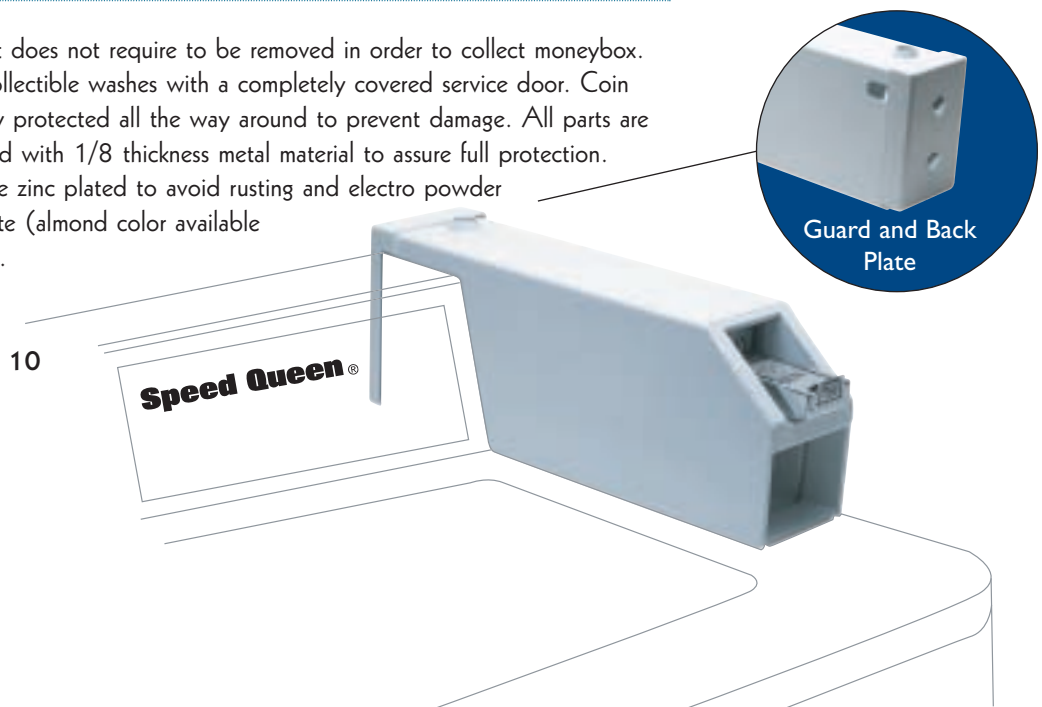

# EXTENDED BACK GUARD BODY

## Closed Front

Close front is more secure by full protection of the money box. Guard body needs to be removed in order to collect money box. Avoid uncollectible washes with a completely covered service door. Coin Slide is fully protected all the way around to prevent damage. All parts are manufactured with 1/8 thickness metal material to assure full protection.

No. EB - 15

All parts are zinc plated to avoid rusting and electro powder coating white (almond color available by request).

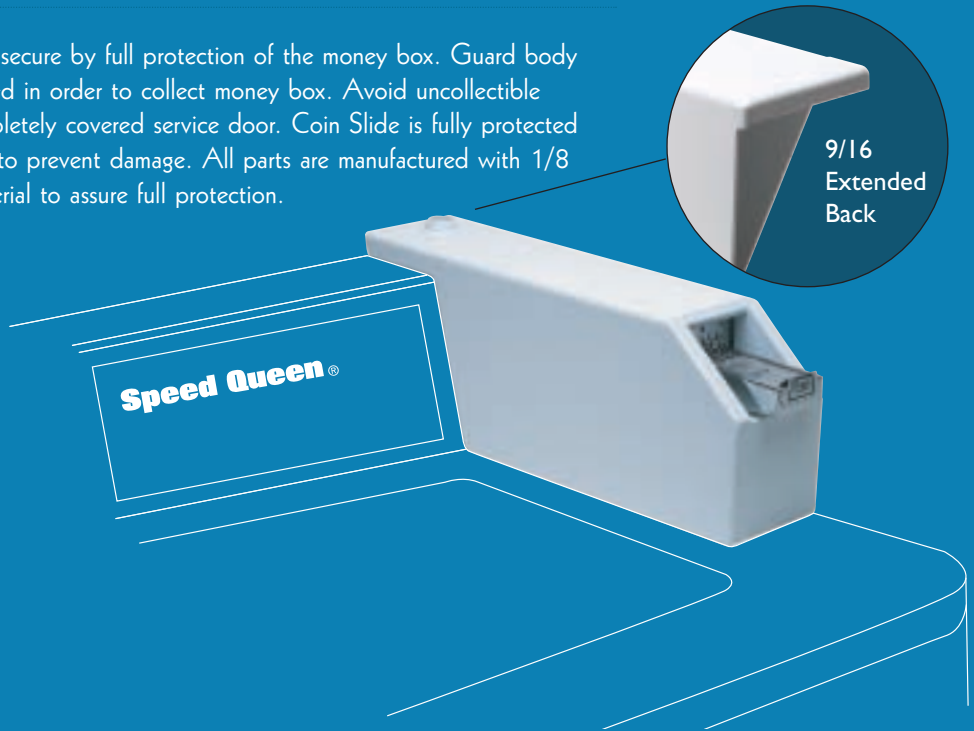

# GUARD AND BACKPLATE

## Closed Front

Close front is more secure by full protection of the money box. Guard body needs to be removed in order to collect money box. Avoid uncollectible washes with a completely covered service door. Coin Slide is fully protected all the way around to prevent damage. All parts are manufactured with 1/8 thickness metal material to assure full protection. All parts are zinc plated to avoid rusting and electro powder coating white (almond color available by request).

No. GB - 15

Back plate gives you full security on the back, bolted with two 5/16 x 3/4 step bolts and 2 hex nuts.

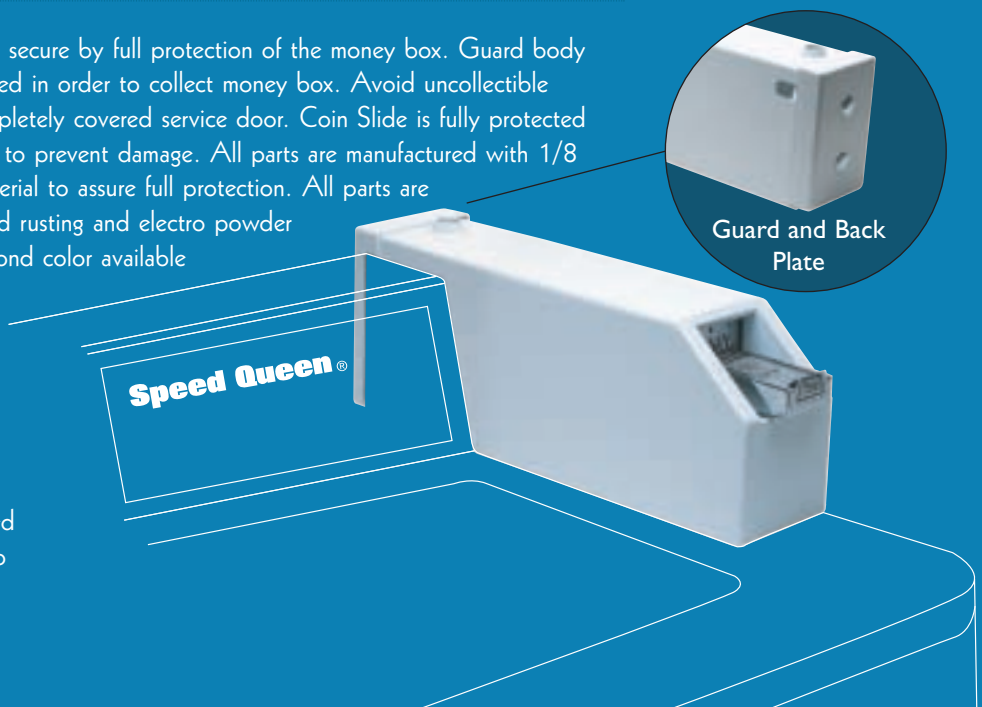

## EXTENDED BACK GUARD BODY

### Coin Drop Open Front™

Open Front does not require to be removed in order to collect moneybox. Avoid uncollectible washes with a completely covered service door. All parts are manufactured with 1/8 thickness metal material to assure full protection.

No. EB - 20

All parts are zinc plated to avoid rusting and electro powder coating white (almond color available by request).

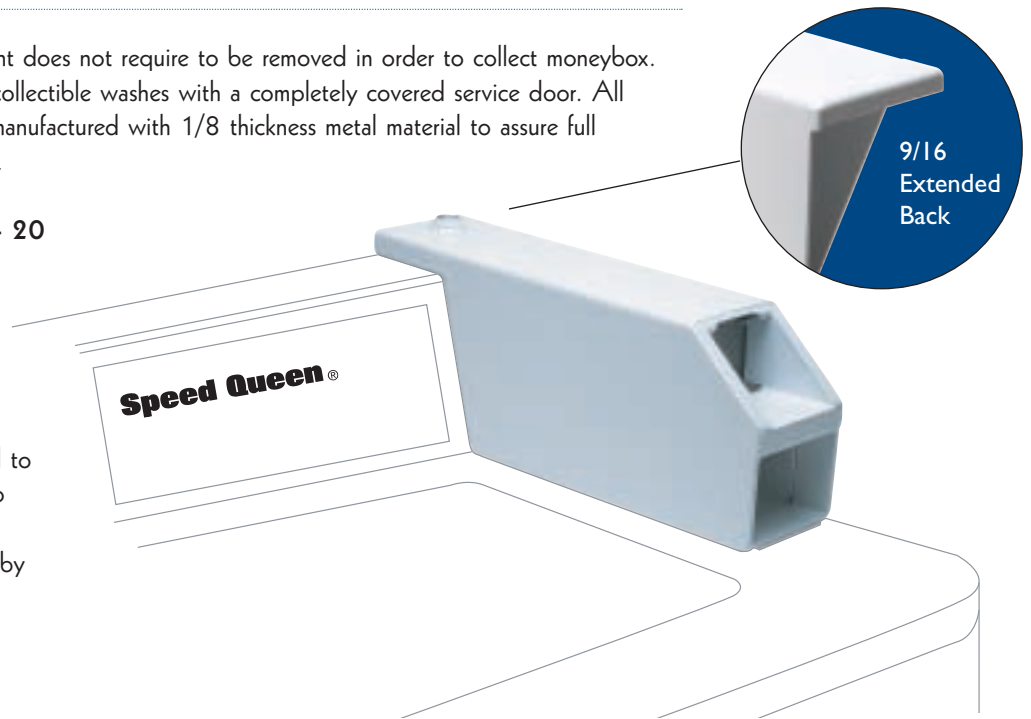

## GUARD AND BACKPLATE

### Coin Drop Open Front™

Open Front does not require to be removed in order to collect moneybox. Avoid uncollectible washes with a completely covered service door. All parts are manufactured with 1/8 thickness metal material to assure full protection. All parts are zinc plated to avoid rusting and electro powder coating white (almond color available by request).

No. GB - 20

Back plate gives you full security on the back, bolted with two 5/16 x 3/4 step bolts and 2 hex nuts.

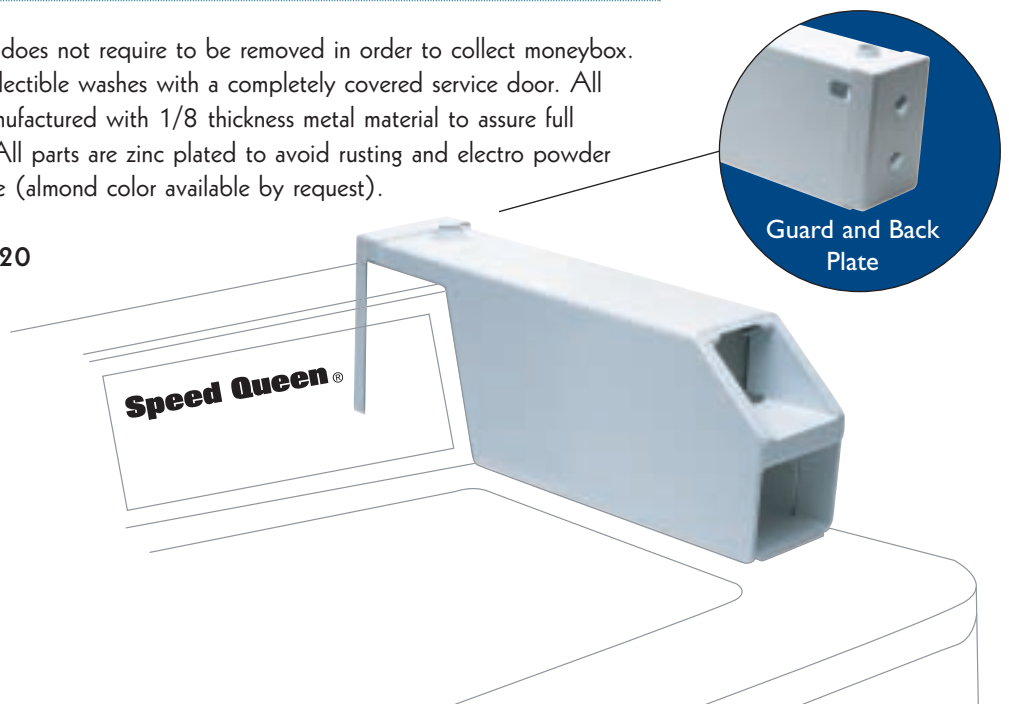

# EXTENDED BACK GUARD BODY

## Coin Drop Closed Front

Close front is more secure by full protection of the money box. Guard body needs to be removed in order to collect money box. Avoid uncollectible washes with a completely covered service door. All parts are manufactured with 1/8 thickness metal material to assure full protection.

No. EB - 25

All parts are zinc plated to avoid rusting and electro powder coating white (almond color available by request).

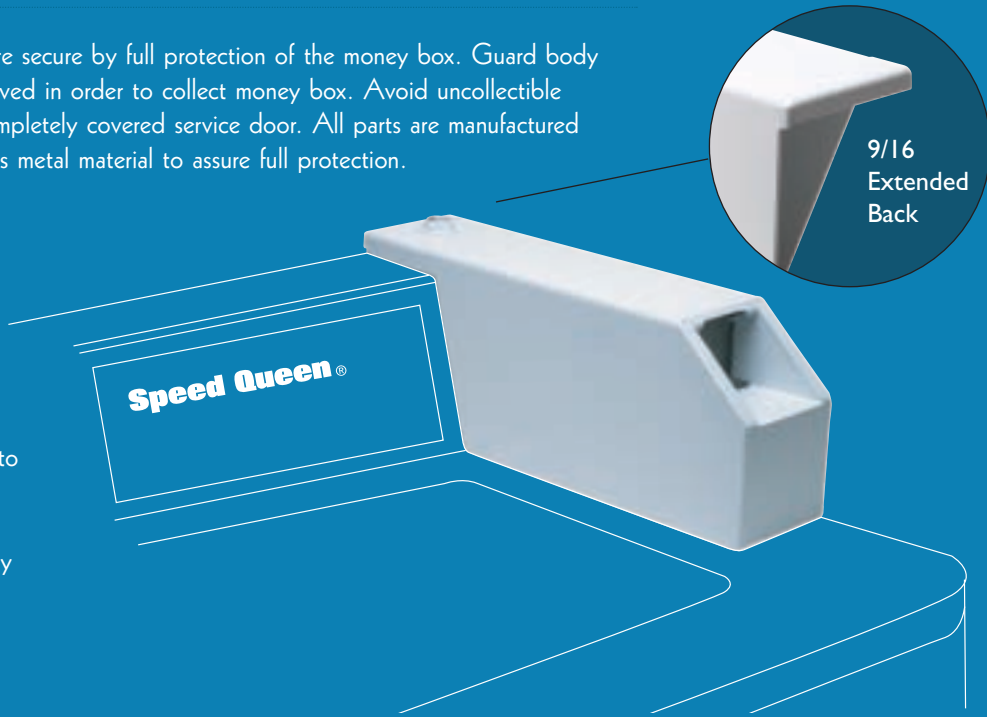

# GUARD AND BACKPLATE

## Coin Drop Closed Front

Close front is more secure by full protection of the money box. Guard body needs to be removed in order to collect money box. Avoid uncollectible washes with a completely covered service door. All parts are manufactured with 1/8 thickness metal material to assure full protection. All parts are zinc plated to avoid rusting and electro powder coating white (almond color available by request).

No. GB - 25

Back plate gives you full security on the back, bolted with two 5/16 x 3/4 step bolts and 2 hex nuts.

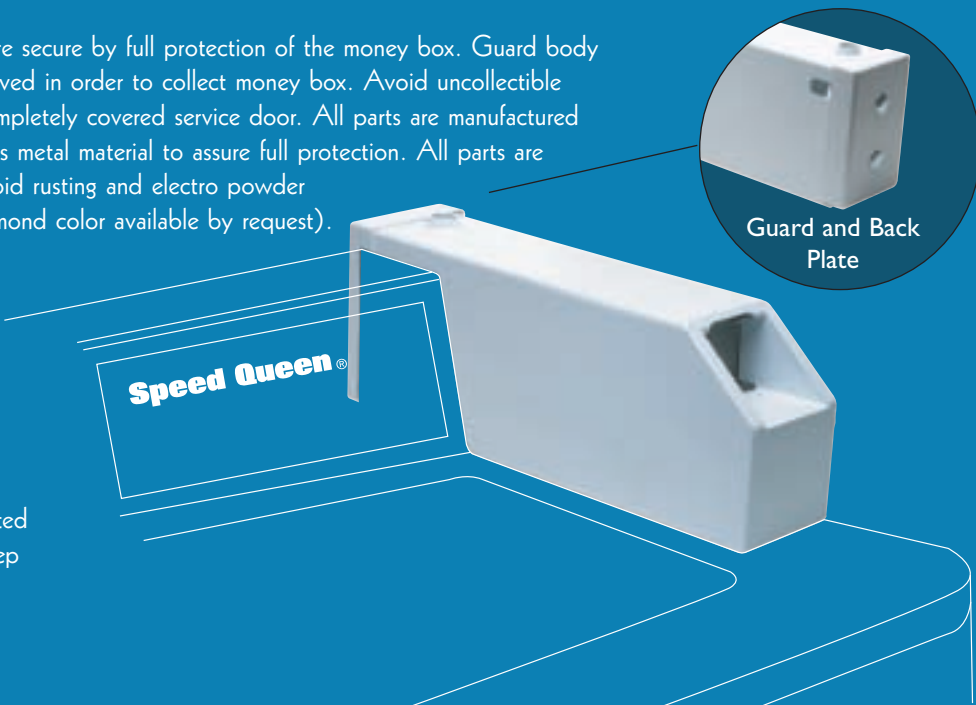



## STACK UNIT

### Open Front™

Open Front does not require to be removed in order to collect moneybox. Completely covered Service door. Coin Slide is fully protected all the way around to prevent damage. All parts are manufactured with 1/8 thickness metal material to assure full protection. All parts are zinc plated to avoid rusting and electro powder coating white (almond color available by request).

No. ST - 100

#### Requirements:

2 x LSQ - 3



2 x LG - 105

### Closed Front™

Close front is more secure by full protection of the money box. Guard body needs to be removed in order to collect money box. Completely covered service door. Coin Slide is fully protected all the way around to prevent damage. All parts are manufactured with 1/8 thickness metal material to assure full protection. All parts are zinc plated to avoid rusting and electro powder coating white (almond color available by request).

No. ST - 105

#### Requirements:

2 x LSQ - 3



2 x LG - 105

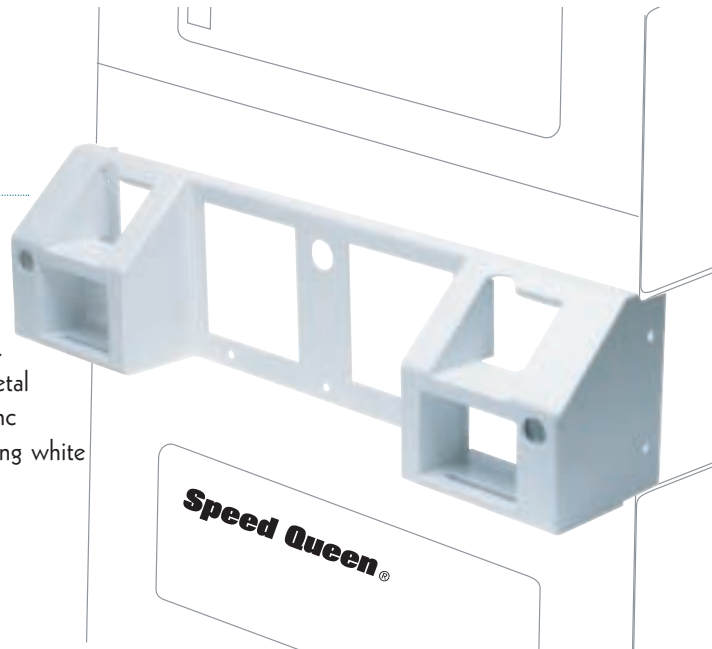

Also Available for:

**Whirlpool®**

No. ST - 110

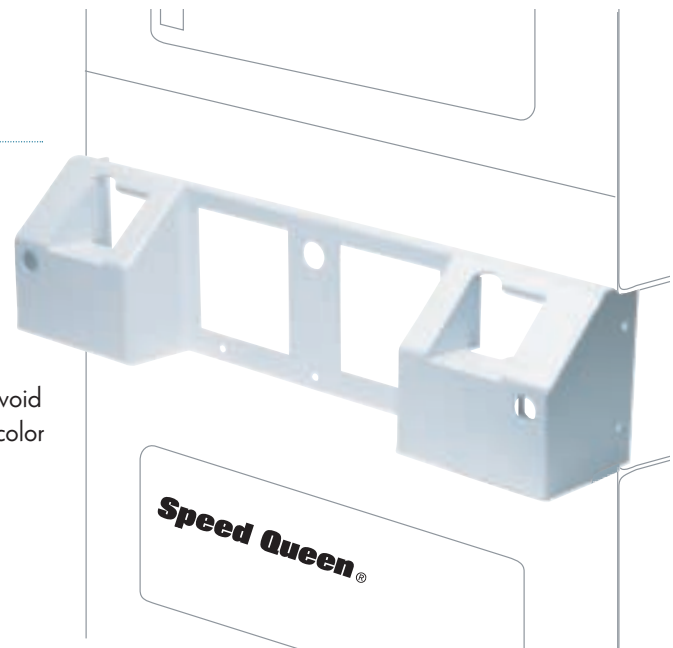

Also Available for:

**Whirlpool®**

No. ST - 115

# STACK UNIT

## Open Front™

Open Front does not require to be removed in order to collect moneybox. Covered Service door. Coin Slide is fully protected all the way around to prevent damage. All parts are manufactured with 1/8 thickness metal material to assure full protection. All parts are zinc plated to avoid rusting and electro powder coating white (almond color available by request).

No. ST - 130

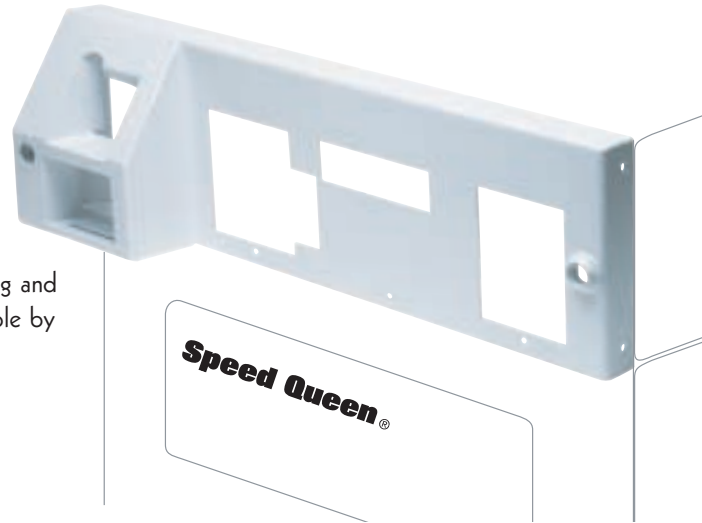

### Requirements:

1 x LSQ - 1



1 x LSQ - 3



1 x LG - 120



1 x LG - 105

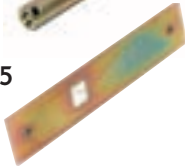

## Closed Front™

Close front is more secure by full protection of the money box. Guard body needs to be removed in order to collect money box. Completely covered Service door. Coin Slide is fully protected all the way around to prevent damage. All parts are manufactured with 1/8 thickness metal material to assure full protection. All parts are zinc plated to avoid rusting and electro powder coating white (almond color available by request).

No. ST - 135

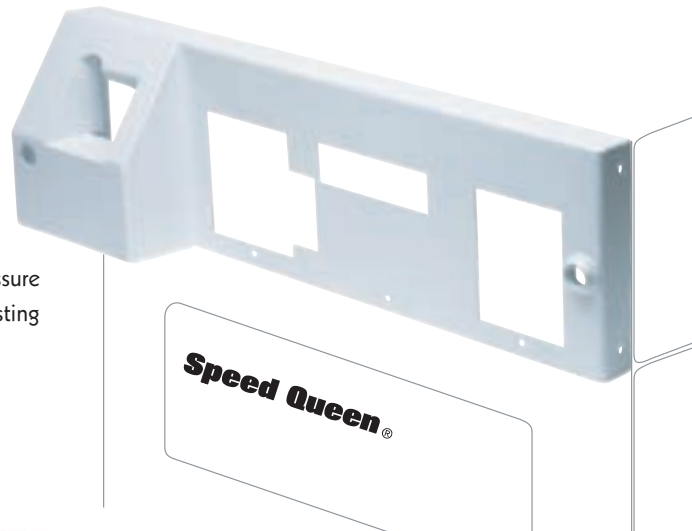

### Requirements:

1 x LSQ - 1



1 x LSQ - 3



1 x LG - 120



1 x LG - 105



## STACK UNIT

### Closed Front

Close front is more secure by full protection of the money box. Guard body needs to be removed in order to collect money box. Completely covered Service door. Coin Slide is fully protected all the way around to prevent damage. All parts are manufactured with 1/8 thickness metal material to assure full protection. All parts are zinc plated to avoid rusting and electro powder coating white (almond color available by request).

No. ST - 120

Requirements:

2 x LSQ - 1



2 x LG - 120



## HALF GUARD

### Half Guard

Coin Slide is fully protected all the way around to prevent damage. All parts are manufactured with 1/8 thickness metal material to assure full protection.

No. G - 150

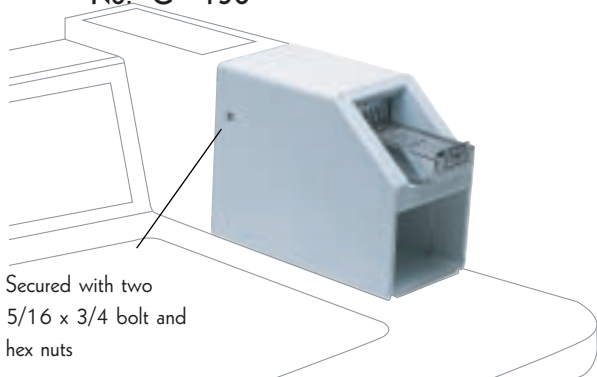

Secured with two 5/16 x 3/4 bolt and hex nuts

### Coin Drop Half Guard

Coin Slide is fully protected all the way around to prevent damage. All parts are manufactured with 1/8 thickness metal material to assure full protection. Works on coin slide and coin drop.

No. G - 155

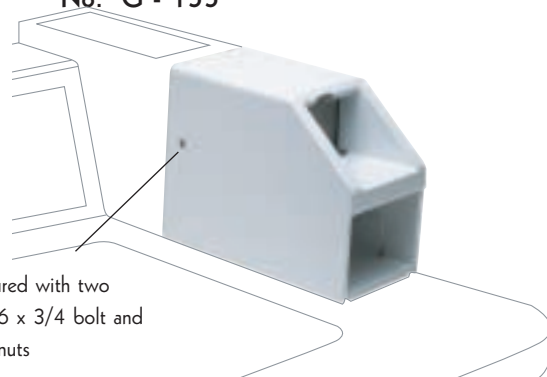

Secured with two 5/16 x 3/4 bolt and hex nuts



Also Available for:

No. G - 175

No. G - 165 (Old Style)  
No. G - 170 (New Style)

No. G - 160 (Old Style)  
No. G - 180 (New Style)

# GUARD AND BACKPLATE



## Coin Drop Open Front

Open Front does not require to be removed in order to collect moneybox. Avoid uncollectible washes with a completely covered service door. Coin Slide is fully protected all the way around to prevent damage. All parts are manufactured with 1/8 thickness metal material to assure full protection. All parts are zinc plated to avoid rusting and electro powder coating white (almond color available by request).

No. GB - 90

Back plate gives you full security on the back, bolted with two 5/16 x 3/4 step bolts and 2 hex nuts.

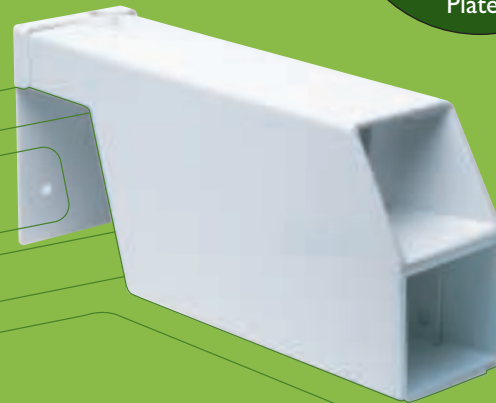

Guard and Back Plate

## Coin Drop Closed Front

Close front is more secure by full protection of the money box. Guard body needs to be removed in order to collect money box. Avoid uncollectible washes with a completely covered service door. Coin Slide is fully protected all the way around to prevent damage. All parts are manufactured with 1/8 thickness metal material to assure full protection. All parts are zinc plated to avoid rusting and electro powder coating white (almond color available by request).

No. GB - 95

Back plate gives you full security on the back, bolted with two 5/16 x 3/4 step bolts and 2 hex nuts.

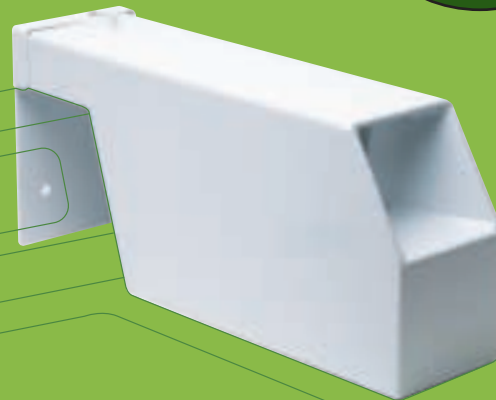

Guard and Back Plate

# EXTENDED BACK GUARD BODY

## New Style Open Front™

Open Front does not require to be removed in order to collect moneybox. Avoid uncollectible washes with a completely covered service door. Coin Slide is fully protected all the way around to prevent damage. All parts are manufactured with 1/8 thickness metal material to assure full protection. All parts are zinc plated to avoid rusting and electro powder coating white (almond color available by request).

No. EB - 60

**Also available for  
Maytag Old Style  
No. EB - 50**

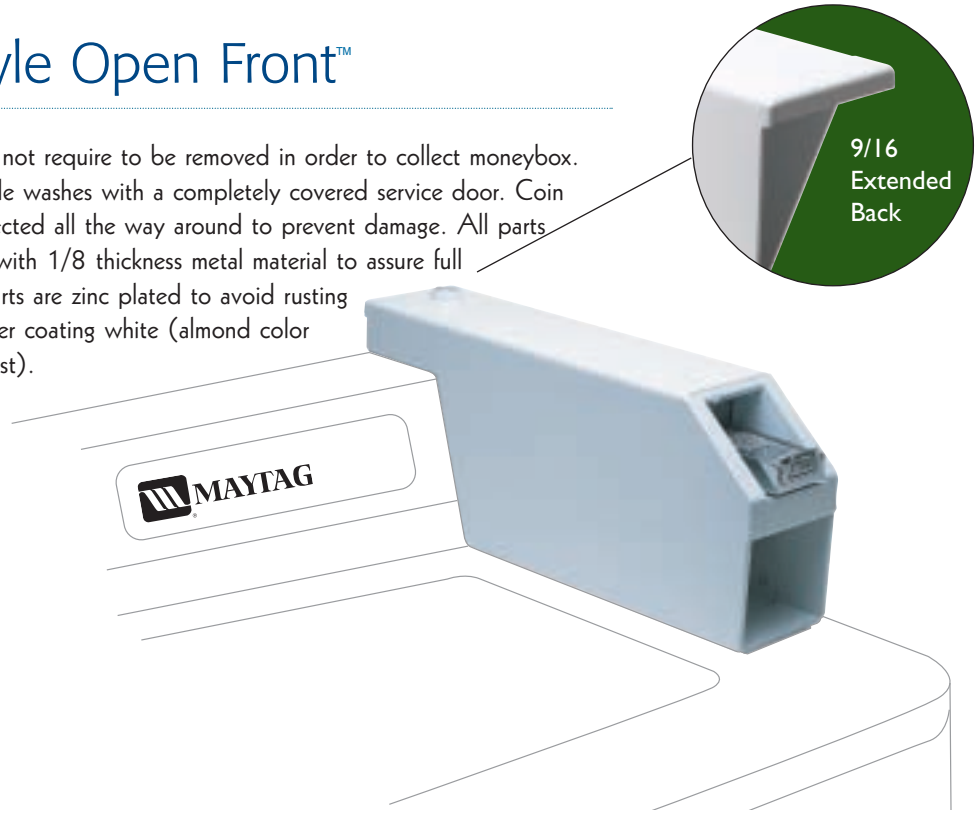

# GUARD AND BACKPLATE

## New Style Open Front™

Open Front does not require to be removed in order to collect moneybox. Avoid uncollectible washes with a completely covered service door. Coin Slide is fully protected all the way around to prevent damage. All parts are manufactured with 1/8 thickness metal material to assure full protection. All parts are zinc plated to avoid rusting and electro powder coating white (almond color available by request).

No. GB - 60

**Also available for  
Maytag Old Style  
No. GB - 50**

Back plate gives you full security on the back, bolted with two 5/16 x 3/4 step bolts and 2 hex nuts.

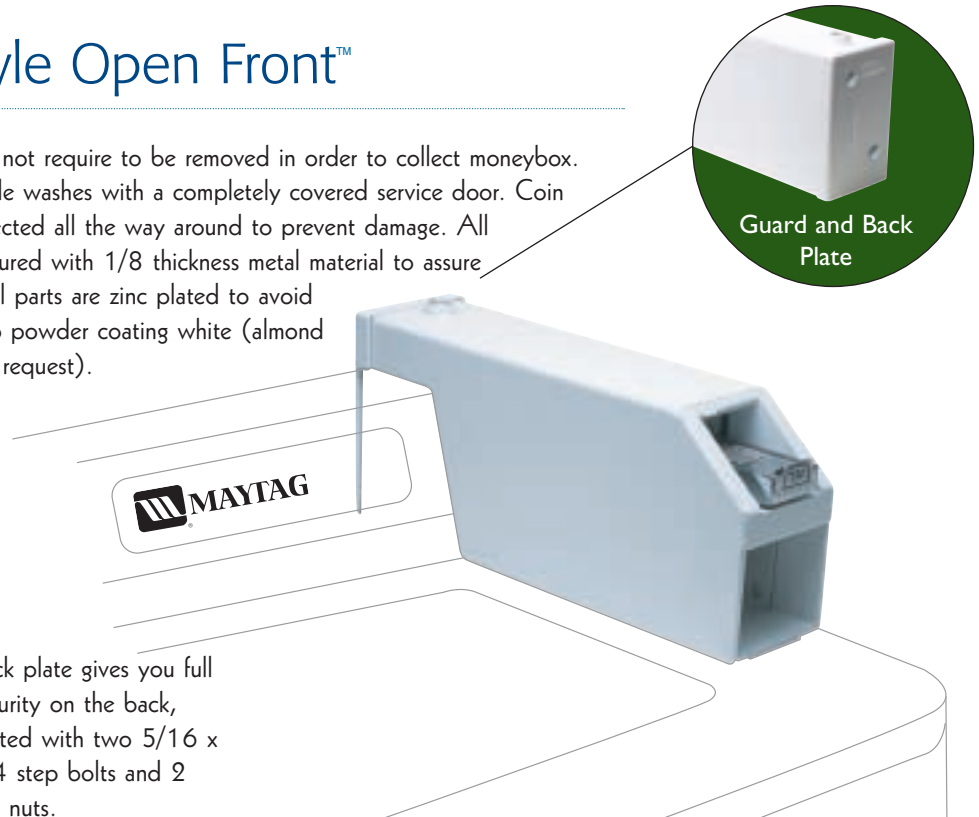

# EXTENDED BACK GUARD BODY



## New Style Closed Front

Close front is more secure by full protection of the money box. Guard body needs to be removed in order to collect money box. Avoid uncollectible washes with a completely covered service door. Coin Slide is fully protected all the way around to prevent damage. All parts are manufactured with 1/8 thickness metal material to assure full protection. All parts are zinc plated to avoid rusting and electro powder coating white (almond color available by request).

No. EB - 65



9/16  
Extended  
Back



Also available for  
Maytag Old Style  
No. EB - 55

# GUARD AND BACKPLATE

## New Style Closed Front

Close front is more secure by full protection of the money box. Guard body needs to be removed in order to collect money box. Avoid uncollectible washes with a completely covered service door. Coin Slide is fully protected all the way around to prevent damage. All parts are manufactured with 1/8 thickness metal material to assure full protection. All parts are zinc plated to avoid rusting and electro powder coating white (almond color available by request).

No. GB - 65



Guard and Back  
Plate

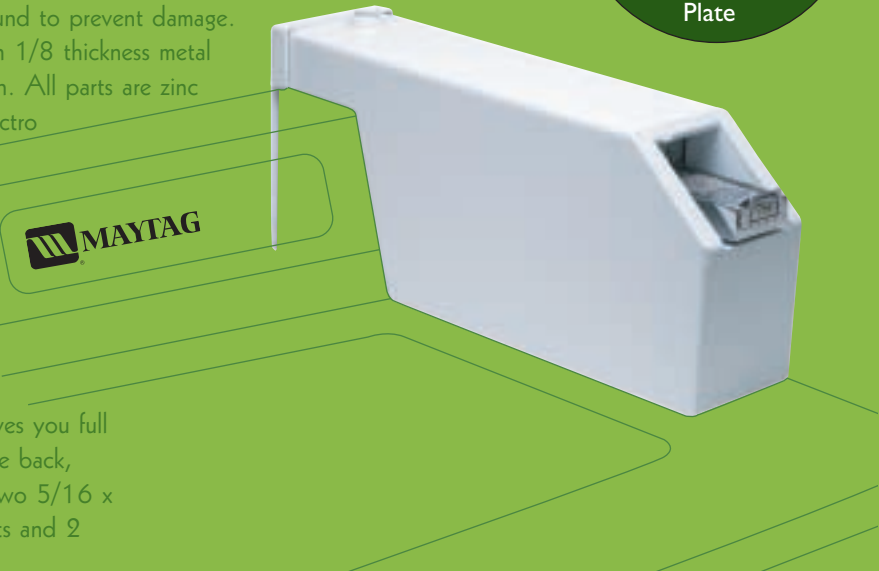

Also available for  
Maytag Old Style  
No. GB - 55

Back plate gives you full security on the back, bolted with two 5/16 x 3/4 step bolts and 2 hex nuts.

# EXTENDED BACK GUARD BODY

## Washer Open Front™

Open Front does not require to be removed in order to collect moneybox. Avoid uncollectible washes with a completely covered service door. Coin Slide is fully protected all the way around to prevent damage. All parts are manufactured with 1/8 thickness metal material to assure full protection. All parts are zinc plated to avoid rusting and electro powder coating white (almond color available by request).



No. EB - 70

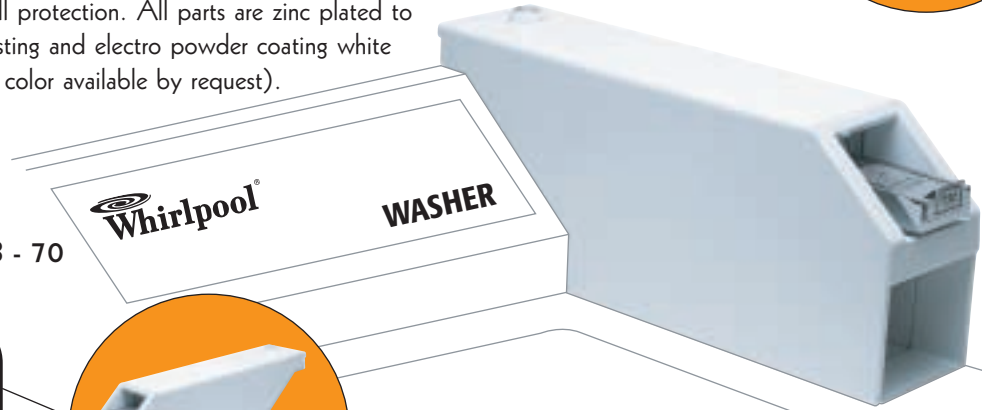

Also available for  
Whirlpool Dryers  
No. EB - 80

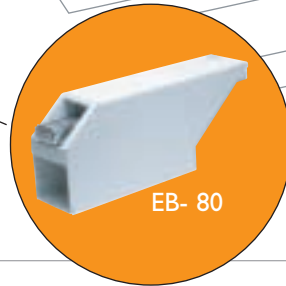

# GUARD AND BACKPLATE

## Washer Open Front™

Open Front does not require to be removed in order to collect moneybox. Avoid uncollectible washes with a completely covered service door. Coin Slide is fully protected all the way around to prevent damage. All parts are manufactured with 1/8 thickness metal material to assure full protection. All parts are zinc plated to avoid rusting and electro powder coating white (almond color available by request).



No. GB - 70

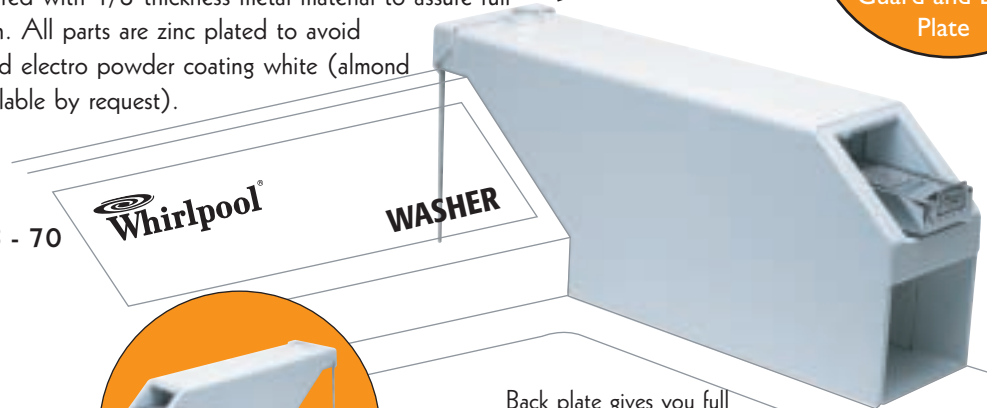

Also available for  
Whirlpool Dryers  
No. GB - 80

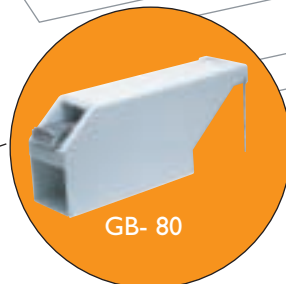

Back plate gives you full security on the back, bolted with two 5/16 x 3/4 step bolts and 2 hex nuts.

# EXTENDED BACK GUARD BODY



## Washer Closed Front

Close front is more secure by full protection of the money box. Guard body needs to be removed in order to collect money box. Avoid uncollectible washes with a completely covered service door. Coin Slide is fully protected all the way around to prevent damage. All parts are manufactured with 1/8 thickness metal material to assure full protection. All parts are zinc plated to avoid rusting and electro powder coating white (almond color available by request).



No. EB - 75

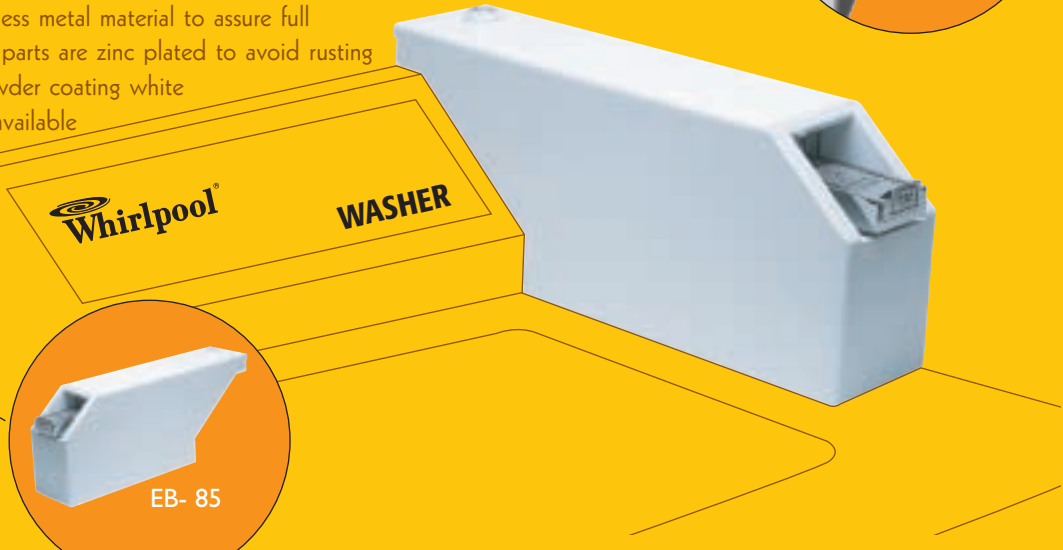

**Also available for  
Whirlpool Dryers  
No. EB - 85**



# GUARD AND BACKPLATE

## Washer Closed Front

Close front is more secure by full protection of the money box. Guard body needs to be removed in order to collect money box. Avoid uncollectible washes with a completely covered service door. Coin Slide is fully protected all the way around to prevent damage. All parts are manufactured with 1/8 thickness metal material to assure full protection. All parts are zinc plated to avoid rusting and electro powder coating white (almond color available by request).



No. GB - 75

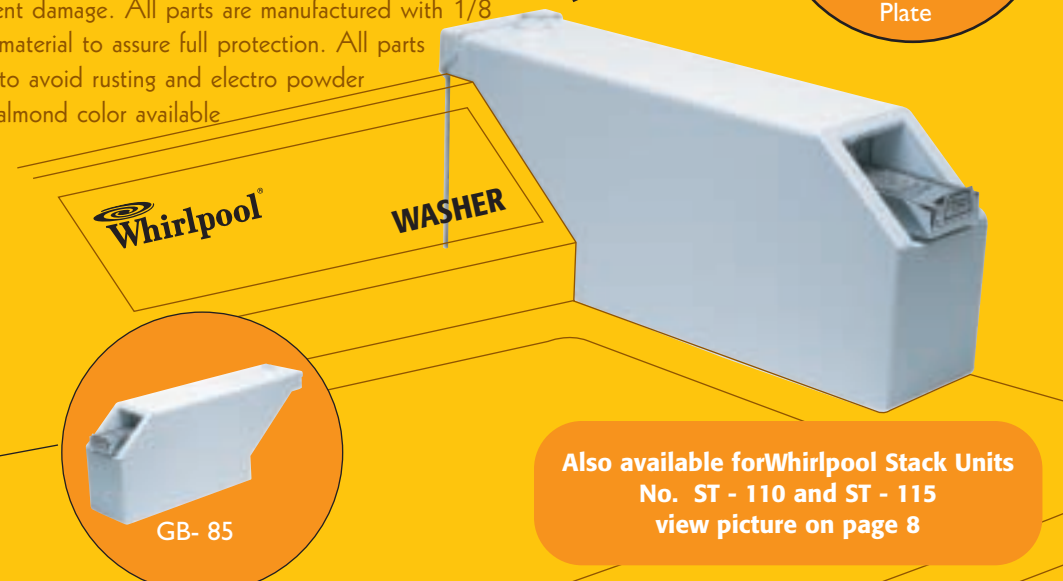

**Also available for  
Whirlpool Dryers  
No. GB - 85**



**Also available for Whirlpool Stack Units  
No. ST - 110 and ST - 115  
view picture on page 8**





## LOCK SHAFT

### Full Turn

5/16 Lock Shaft.

No. LSQ - 1



### 1/4 Turn

1/4 Turn Lock Shaft only.

No. LSQ - 2



### Stack Long Shaft

3" long Lock Shaft used for stack guard bodies.

No. LSQ - 3



## LOCK GUIDES

### Speed Queen

Lock Guide secures meter cage and guard body together. Works on all Speed Queen guard bodies.

No. LG - 10

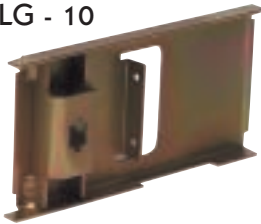

### GE

Lock Guide secures meter cage and guard body together. Works on all GE guard bodies.

No. LG - 15



### Whirlpool

Lock Guide secures meter cage and guard body together. Works on all Whirlpool guard bodies.

No. LG - 30

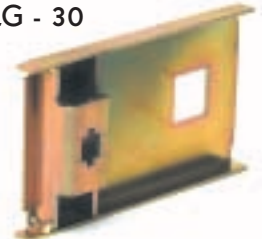

### Maytag

Lock Guide secures meter cage and guard body together. Works on all Maytag guard bodies.

No. LG - 20 (Old Style)

No. LG - 25 (New Style)

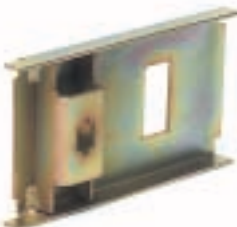

### Speed Queen Stack Units

Lock Guide secures meter cage and guard body together. Works on Speed Queen Stack Units ST-100 and ST-105.

No. LG - 105

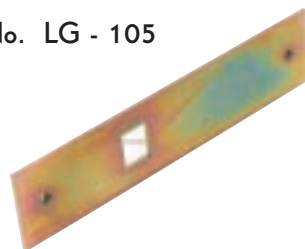

### Speed Queen Stack Units

Lock Guide secures meter cage and guard body together. Works on Speed Queen Stack Units ST-120 and ST-130.

No. LG - 120



# HARDWARE

## Hold Down Plate

Holds top and side panel together to avoid being separated apart. Manufactured with 7 gage material tickness to assure full protection.

No. HD - 10

Size 2 1/2"x4"

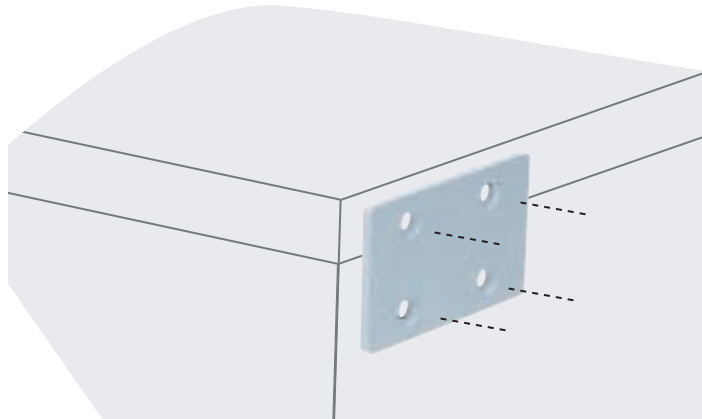

## Hold Down Plate

Holds top and side panel together to avoid being separated apart. Manufactured with 7 gage material tickness to assure full protection. Size 4"x6".

No. HD - 15

Requires two back-up plates.



## Hold Down Plate

Holds top and side panel together to avoid being separated apart. Manufactured with 7 gage material tickness to assure full protection. Size 4"x8".

No. HD - 20

Requires two back-up plates.



## 5/16 Cage Nut

Works on all lock guides when using a full turn lock shaft.



## Step Bolt

No. LG - 20  
(Old Style)

No. LG - 25  
New Style



## SIDE PLATES

### Model 1

Side plate secure meter and top to cabinet. Fastened with (3) step bolts and nuts.

No. SP - 1  
Speed Queen

No. SP - 2  
GE New Style

No. SP - 3  
Maytag New Style



### Maytag Side Plate

Side plate secure meter and top to cabinet. Fastened with (2) step bolts and nuts.

No. SP - 9



### WP New Style Washer

Side plate secure meter and top to cabinet. Fastened with (3) step bolts and nuts.

No. SP - 6  
Whirlpool New Style  
Washer

No. SP - 4  
GE Old Style



### WP Old Style Washer

Side plate secure meter and top to cabinet. Fastened with (3) step bolts and nuts.

No. SP - 7  
Whirlpool Old Style  
Washer



### Whirlpool Dryer

Side plate secure meter and top to cabinet. Fastened with (3) step bolts and nuts.

No. SP - 8



### Maytag Old Style

Side plate secure meter and top to cabinet. Fastened with (3) step bolts and nuts.

No. SP - 5



# MONEY BOX COVER

## Guard Body Door

Guard Body Door provides extra security to the money box on all open front guards.

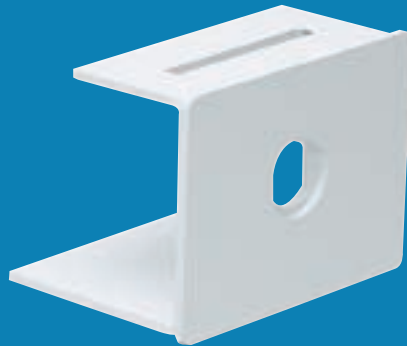

Available for:

**Speed Queen®**

No. S - 12



No. S - 32



No. S - 62



No. S - 72

## Money Box Cover

Protects the money box area. Does not require a guard body.

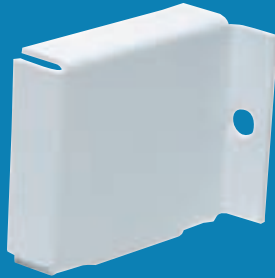

Available for:

**Speed Queen®**

No. MBC - 10



No. MBC - 15



No. MBC - 20



No. MBC - 25

## Speed Queen Stack Unit Money Protector

Provides extra security to the money box on all Speed Queen stack units.

No. STC - 100

